

**GLOBAL
FLEXIBLE
POWER
SOLUTIONS**

For:

- Data Centers •
- Industrial/Marketing •
- Engineering/Test Labs •
- Retail Outlets •
- Production & Assembly •



Starline Track Busway...

STARLINE Track Busway™ is quickly becoming the industry standard for power distribution systems. Introduced in 1988, this innovative system is a modular, overhead, “build-as-needed,” electrical distribution system that gives you the ability to change or add to floor plans quickly and easily — **without any down time!!** And because it is an overhead system, there isn’t a jungle of wires to obstruct air flow under the floor — making STARLINE Track Busway one of the most energy efficient systems you can buy.

The track busway concept refers to the continuous access plug-in slot or “track” in the bottom of the busway sections. Plug-in units can be inserted into the busway at the “point-of-use,” as close together or far apart as desired. Product design is in accordance with NEC Article 368, conforms with IEC standard for busways, standard systems are UL Listed, and is ISO 9001-2000 compliant, for quality standards.

Plug-in units include simple duplex receptacles, circuit breakers, fused disconnects, drop cords with cord receptacles, or quad boxes and power poles in a wide variety of configurations and three-phase disconnects. Multiple receptacle plug-in units are available for high-density applications.

Fast Installation and Reconfiguration

STARLINE’s preassembled modular design can be installed in a fraction of the time compared to the conventional conduit and wire method and at a *considerable cost savings*. In fact, many contractors and facility owners report total installed cost savings of 20-40% or more, and labor time reductions are 30-50% over their estimates for conduit and wire, industrial bus duct and other methods.

All system components can be disassembled and reused at new locations. Plug-in units can be added, removed or relocated instantly by in-house personnel with no additional installation costs, and **without shutting down power**.

System Capacities (all shown as three-phase)

(For more information on systems please refer to the Product Selection Guide)

System No.	Amps	Volts	Neutral	ISO GRD.	Size
GM100NG	100	415	200%	Yes	106mm x 66mm
GM100	100	415	100%	No	106mm x 66mm
GM100G	100	415	100%	No	106mm x 66mm
GM225	225	415	100%	No	106mm x 66mm
GM225G	225	415	100%	Yes	106mm x 66mm
* GM400/GM400G	400	415	100%	No	128mm x 145mm
* GM400NG/GM400N	400	415	150%	Yes	128mm x 145mm

* IEC Pending

Typical System Design

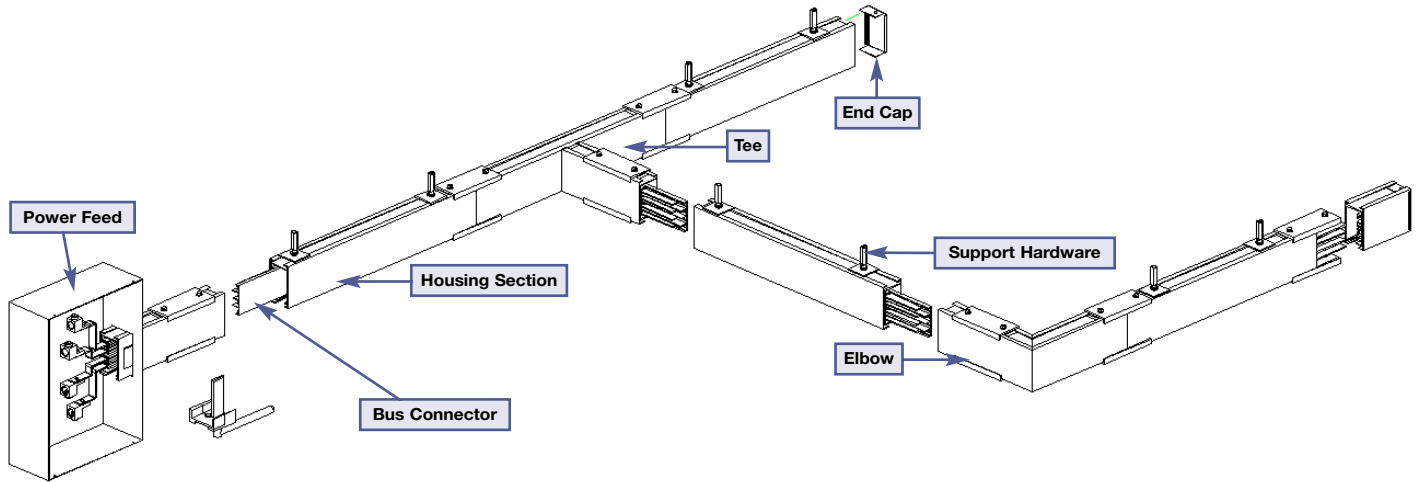

Reliability is the backbone design criteria for all STARLINE Track Busway systems. The unique compression connection concept at the connection points assures that the connections run cooler than the conductor busbar itself. STARLINE's patented technology provides a system that requires no routine maintenance.

Scalability allows the user to install only what is needed without tying up capital funds for initial unneeded material. The user can simply add to busway sections and plug-in units as the need arises OR simply relocate a unit or system quickly and easily without having to rewire. STARLINE Track Busway improves your ability to make future facility changes easily, making it one of today's most "green" products on the market.

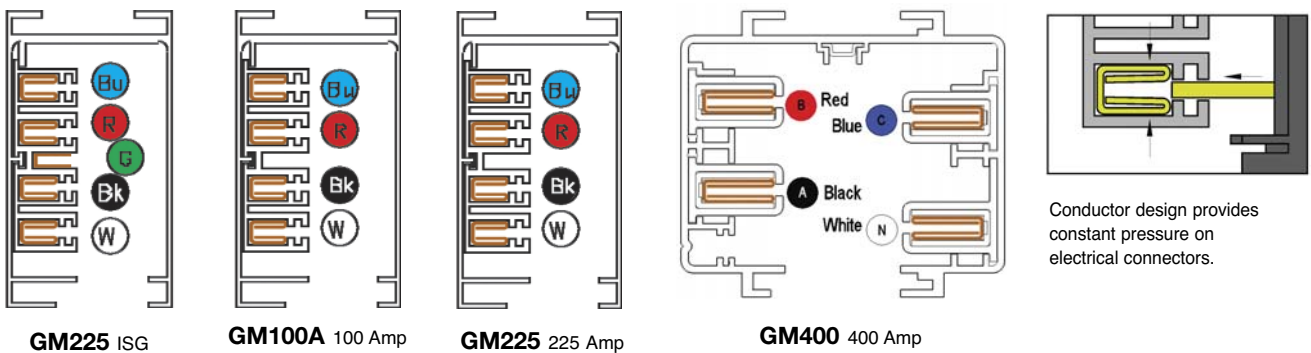

Your Flexible Power Solution...

From...

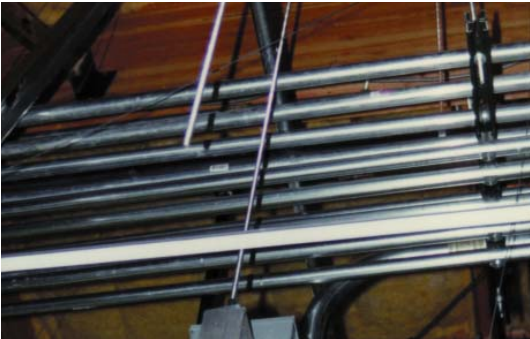

Conduit and Wire

Must be scrapped whenever reconfiguration of the electrical layout is needed. Many runs may be needed for applications with a high volume or high-density of electrical loads. It is labor intensive to install or add more loads, and typically requires a high number of homeruns.



Wire and Cable Whips

Can easily become a confusing jungle which can not be maintained or relocated as facility electrical requirements change. The cost of power outages and running replacements or new cables can be extremely expensive.



Bus Duct, Cable Trays, Overhead or Under Floor Raceways, Strut or Channel Systems

Are difficult to relocate electrical loads and can end up with far more wires and homeruns. The old, conventional industrial bus duct systems are much larger, heavier, harder to work with and expensive.

To...

**For 16, 32 or 63 Amp, 415 Volt,
Single or Three-Phase**

Flexible & Scalable

STARLINE Track Busway is an investment that allows you to expand, reconfigure or relocate the system anywhere you need power quickly and easily – and often without outside labor costs. And, whether it's a light fixture, outlet box, drop cord or pigtail, adding or moving plug-in units are simple – just insert the plug-in unit into the busway and snap it into a locked position.



**For 16, 32 or 63 Amp, 415 Volt,
Single or Three-Phase**

Sustainable

STARLINE Track Busway gives you the ability to change or add to floor plans quickly and easily **without any downtime!** And, because it's an overhead system, there is no "jungle" of wires to obstruct air flow under the floor – making it one of the most energy efficient systems you can buy in today's "green build" environment.



**For 100, 160, 225 Amp or 400, 415 Volt,
Single or Three-Phase**

Relocatable

STARLINE Track Busway makes installation and relocation quick and easy, and lowers costs because it takes less time to install – cutting labor costs dramatically. STARLINE Track Busway is aesthetically appealing and light weight as compared to traditional systems. Also, plug-in units are so easy to install that outside labor is often not necessary.



In any Industry...



Industrial Manufacturing & Assembly Plants

The design flexibility and the ability to make changes quickly and easily have made STARLINE the electrical distribution and factory lighting standard by today's leading manufacturers and high-tech companies. Entire systems can be set-up in a matter of hours with relocation of power drops in minutes, often without outside labor.



College Engineering Labs & Vo-Tech Shops

Quick change over and the ability to plug-in the widest possible selection of plug-in units on the same system, often at different voltages, has made STARLINE the system of choice for Engineering and Research Labs at leading Universities, Colleges, and Vo-Tech Shops.



Retail Outlets

STARLINE's Compact Series is ideal for retail power supply and lighting. The "snap-in" plug allows the retail owner to use any light fixture. Retail-style drop cords or power poles provide single or three-phase power to aisles, gondolas, check-outs and perimeters throughout the store.

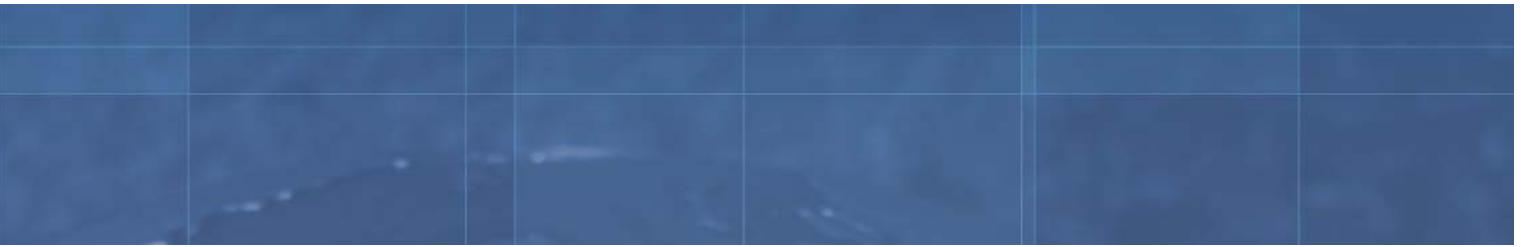

Test Labs

Custom plug-in units shown here with breakers and dual drop cords solve a high-density problem. Custom units can often be designed to meet special customer needs, with quick availability and reasonable cost.



“Mission Critical” Data Centers

The compression busbar connection design is a prime reason why STARLINE has superior reliability and is the chosen electrical backbone for data centers and co-location sites throughout the world. Scalability allows the user to add additional busway sections and plug-in units as sites are filled up over time.



High-Tech Production & Assembly

Work stations, scientific equipment, test equipment and computers are typically located throughout high-tech facilities, including electronics, circuit board manufacturers, aerospace, bio-medical facilities, clean rooms, and other high-tech industries. STARLINE puts the power where you need it, specifically when a high-density of plug-in units and frequent reconfigurations are required.





Universal Electric Corporation has been a leader in power distribution since 1924. The company's founders led the way for many new technologies in the power distribution equipment industry. Today, this family tradition of innovation continues to pave the way for safer, more convenient, electrical power distribution systems.

Other Universal Electric Corporation products include Starline Plug-In Raceway and U-S Safety Trolley. Visit www.uecorp.com for your **Flexible Power Solutions**.

For installation details, RS Means Electrical Estimating cost comparisons, and actual case histories of projects where savings with STARLINE have been documented, contact Universal's customer service department at + 01 412-579-7800.



168 Georgetown Rd.
Canonsburg, PA 15317 U.S.A.
Phone: + 01 412-579-7800
www.uecorp.com

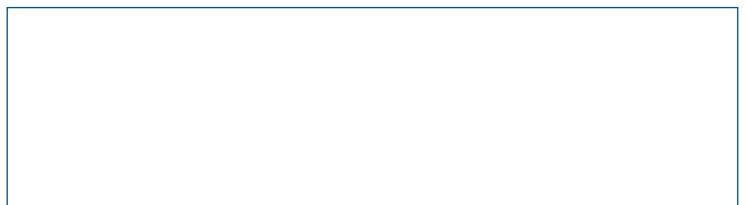

Most Starline systems and most standard components are UL or ETL Listed.